

Guidelines for Making Religious Places Accessible



सत्यमेव जयते

Chief Commissioner
for Persons with Disabilities



DIGNITY FOR PEOPLE
WITH REDUCED MOBILITY



Guidelines for Making Religious Places Accessible

Authored & Edited by: Subhash Chandra Vashishth

Content collation: Navin Kumar Nayan, Anwar Huda

Designed by: Bhupinder Singh

Published & Distributed jointly by :

Svayam - Global Centre for Inclusive Environments (an initiative of Sminu Jindal Charitable Trust) and

**Office of the Chief Commissioner for persons with Disabilities,
Govt of India.**

Year : 2019, Edition -1.1, Copyright ©Svayam

Contents

Founder's Message	1
Message from Chief Commissioner for Persons with Disabilities	2
Editor's Note	3
Introduction	4
General	4-5
Accessible Information	5
Parking	6
Walking Pathways	7
Information/Reception Counter	7-8
Cloak Room	8
Accessible Washroom	9-10
Accessible Squat Toilet	11
Urinals	12
Ablution/Cleaning Space	12
Accessible Changing Room	13
Entrance	14
Door	14
Circulation Area	15
Seating Benches	15
Tactile Ground Surface Indicators	15-16
Ramp	16
Stairs	17
Lift	18
Vertical and Inclined Lifting Platforms	19
The Worship Space	19
Access to Rituals, Accessible Counters/ Shops	20
Public Address System, Staff Training	20
Transportation/Mobility	20
Access to Langar / Bhandara / Prasad	20
Access to Sanctum Sanctorum / Deity Visual Access Including hearing impaired devotees	21
Accessible Seating	21
Religious displays, exhibition areas and galleries	21
Signage and Wayfinding	22
Safe Egress and Evacuation for People with Disabilities	23
Glossary	23-24

Founder 's Message

Though devotees of various faiths can also pray at their homes, religious shrines offer a sense of bonding, atmosphere for prayer, community life, and a powerful connect with the Supreme Being as well as one's own self. Hence, devotees are required to congregate at their respective religious places to pray together.

India is the most diverse country with so many faiths, and this diversity makes it beautiful. We have Temples, Gurudwaras, Mosques, Fire Temples, Churches, Synagogues, as well as tombs of famous Sufi Saints (Dargah). All of them emanate the message of humanity and remind us of our rich heritage.

But most of the religious places are not accessible for devotees and visitors with disabilities and other reduced mobility such the elderly, injured, sick, women and children.

Religions had have been the most dominant force in human lives since time immemorial. People find strength, solace and peace in religions. Religions also teach various humanistic qualities like compassion, patience, loving your neighbours and empowerment of weaker sections of the societies.

As India is marching ahead in terms of accessibility at public places, transport, and ICT after the launch of the Accessible India Campaign (AIC) in 2015, and the Rights of Persons with Disabilities Act, 2016, time has come when we all should stand united as one force, and make our religious places accessible and inclusive.

I am very happy that Svayam has come up with a ready-to-refer booklet "Making Religious Places Accessible", which is the first-of-its-kind guidelines in the country.

I hope the management committees of various religious places take advantage of the recommendations/tips given in this booklet to achieve universal accessibility standards to make their shrines accessible, so that no one is left behind in their pursuit to spirituality and fulfilling their religious obligations.

I thank the office of the Chief Commissioner for Persons with Disabilities (CCPD) for partnering with Svayam in publishing, releasing and making this booklet available across the country, and motivating the heads of different religious places to follow these guidelines.

Wishing you an inclusive prayer!



Sminu Jindal,
Founder-Chairperson, Svayam
MD, Jindal SAW Ltd.

Message from Chief Commissioner for Persons with Disabilities

डॉ. कमलेश कुमार पाण्डेय
मुख्य आयुक्त
Dr. Kamlesh Kumar Pandey
Chief Commissioner



कार्यालय मुख्य आयुक्त, दिव्यांगजन
दिव्यांगजन सशक्तिकरण विभाग
सामाजिक न्याय और अधिकारिता मंत्रालय
भारत सरकार
Office of the Chief Commissioner for Persons
with Disabilities (Divyangjan)
Department of Empowerment of Persons
with Disabilities (Divyangjan)
Ministry of Social Justice and Empowerment
Govt. of India

Dated: 11th January, 2019

Message

'Bharat' is an eternal nation, which has enlightened the world with its myriad philosophies, knowledge and vision for leading a successful life. This country is full of diversity in terms of religions, traditions, sects and lifestyles, but keeps its higher unity for the cause of National Integration. India is also very spiritually rich nation with the existence of various religious places such as temples, gurudwaras, muths, mosques, churches, etc. where people can offer their prayers/puja and which have become the essential part of our lifestyle.

The Constitution of India has provided various 'acts' and 'laws' to the people of India including the people with disabilities (Divyangjan) for enjoyment of their rights to live a comfortable and dignified life. The Rights of Persons with Disabilities, Act 2016 is one of the important acts enacted by the Parliament of India to empower and strengthen the persons with disabilities. Accessibility of Persons with Disabilities (Divyangjan) to various public places, recreational activities, communication, commutations are one of the important issues covered under Section 40 to 42 of RPwD Act, 2016.

Keeping in view the provisions, the Chief Commissioner of Disabilities has been appointed under Section 74 of the RPwD Act 2016, and has been mandated to promote and safeguard the "Rights of Persons with Disabilities".

Considering the mandate of the Office of CCPD and provisions of the RPwD Act 2016, we are happy to join hands with 'Svayam' an empanelled organization under the Accessible India Campaign (AIC) in publishing and distributing "The Guidelines for Making Religious Places Accessible" among the various stakeholders, policy makers, organizations, etc.

Based on the National Standards, the present guidelines are in short, crisp and easy-to-implement format. We hope that it will help organization/committees/bodies to make their respective religious sites accessible for all.

I also believe that the State Commissioners would find the booklet useful to ensure accessibility of religious places in their respective states.

(Dr. Kamlesh Kumar Pandey)

सरोजिनी हाउस, 6, भगवान दास मार्ग, नई दिल्ली - 110 001, दुरभाष : 23386054, 23388154, Fax : 011-23386006
Sarojini House, 6, Bhagwan Dass Road, New Delhi-110001, Tel. : 23386054, 23388154, Fax : 011-23386006
Email : ccpd@nic.in • Website : www.ccdisabilities.nic.in

Editor's Note

Lack of accessibility at religious places is a major issue today; consequently, not only the devotees with disabilities but also the older adults find their respective places of prayer difficult to access and often have to depend on others for help.

As you must be aware, the UN Convention on the Rights of Persons with Disabilities (UN- CRPD) requires nations to promote equality and dignity for persons with disabilities. Also, after launch of Accessible India Campaign (AIC) in December 2015, and subsequent notification of the Rights of Persons with Disabilities Act 2016, accessibility in public buildings (both private & government) has been made mandatory [Section 45, read with Section 2 (w) & Rights of Persons with Disabilities (RPWD) Rules 2017, Chapter VI, Section-15(1-a)] and religious buildings are covered within the scope of the Act.

The National Building Code of India (NBC) 2016 provides detailed guidance for accessibility in buildings. However, there are no sector specific guidelines to help management committees, authorities responsible for maintenance of religious sites and architects etc. to make these sites accessible. Hence the need of this guideline.

The present effort, humble yet change-making in form of identifying the need and writing the technical content for this guideline is of the access experts at Svayam and is largely based on the National Building Code of India - 2016. In addition, the guideline also provide guidance on accessible Indian squat pan, provision of maximum people allowed per square meter area to avoid stampede, accessible approach to rituals, sanctum sanctorum so that people with disabilities are also able to participate on an equal basis with other in all religious functions, festivities and rituals.

We specially thank the Chief Commissioner for Persons with Disabilities, Ministry of Social Justice and Empowerment, Government of India, for partnering with Svayam in publication and distribution of this guideline booklet to the stakeholders and authorities across the length and breadth of India.

We request all management committees overseeing religious sites, dharmshalas, attached accommodations etc. to make a sustained effort in providing minimum accessibility features at their shrines /place of worship/prayer, as it will not only help the devotees with disabilities, the older adults, women, sick and injured believers but also help in setting new benchmarks of accessible & inclusive religious places for the world!

Subhash Chandra Vashishth
Director,
Svayam - Global Centre for Inclusive Environments

1. Introduction

We pray for peace, solace to soul, for penance and to connect with our own Self and seek God. For centuries, man had been building religious places on the high citadel, far from the neighbourhood, perhaps to create more barriers such as hundreds of stairs, so that they could toil more to shed more sins.

But with the times changed, old concepts have also changed. In the age of social justice, equality and human rights, we not only need to demolish existing barriers to inclusion but also remain conscious so as not to create new barriers – through design or through our thoughts or actions.

Today, when we have the expertise and better available technologies, we can provide equal access to all more easily than before. As all are equal in the Eyes of God, they must also enjoy equal rights to pray despite their abilities, disabilities, age or gender.

Congregational prayers at religious places can provide great comfort to people with disabilities, as it does to everyone else. Also, persons with disabilities have similar desire to seek penance and earn piety as everyone else; hence barriers at religious places need to go away.

It is quite surprising to see that a large section of society is kept away from God and from fulfilling their urge to find solace just because of inaccessible Mosques, Temples, Churches, Gurudwaras, Synagogues and Dargah. Fewer people with disabilities attend religious places /services due to infrastructural barriers in religious buildings. Often, the religious sites have too many stairs, and inaccessible washrooms and ablution area, narrow aisles and uneven surfaces with no ramps.

An accessible religious place does not only help the devotees with disabilities, but also the elderly, sick and injured devotees/visitors. If these places are made accessible and disabled-friendly, it will also meet the spirit of the Accessible India Campaign, as well as the law of the land.

Next sections detail out area wise requirements and key points to be observed while making provisions or designing that particular area.

2. General

Like all public buildings, a religious building too must be accessible to persons with disabilities; its approach roads and pathways, parking space, entrances, main areas of worship (areas near sanctum sanctorum), washrooms, seating areas, cloakrooms and water fountain, etc. should be accessible.

2.1 Law and Policy Mechanism Constitution of India (Art. 25)

Freedom of Religion is a fundamental right guaranteed by Article 25 of the Constitution of India. It specifically provides as under:

25. Freedom of conscience and free profession, practice and propagation of religion.-

(1) Subject to public order, morality and health and to the other provisions of this Part, all persons are equally entitled to freedom of conscience and the right freely to profess, practice and propagate religion.”

2.2 The Rights of Persons with Disabilities Act, 2016

Chapter VIII: Duties And Responsibilities Of Appropriate Governments Section-40. The Central Government shall, in consultation with the Chief Commissioner, formulate rules for persons with disabilities laying down the standards of accessibility for the physical environment, transportation, information and communications, including appropriate technologies and systems, and other facilities and services provided to the public in urban and rural areas.

Section 44. (1) No establishment shall be granted permission to build any structure if the building plan does not adhere to the rules formulated by the Central Government under section 40. (2) No establishment shall be issued a certificate of completion or allowed to take occupation of a building unless it has adhered to the rules formulated by the Central Government.

Section 45. (1) All existing public buildings shall be made accessible in accordance with the rules formulated by the Central Government within a period not exceeding five years from the date of notification of such rules: Provided that the Central Government may grant extension of time to the States on a case to case basis for adherence to this provision depending on their state of preparedness and other related parameters.

2.3 The Rights of Persons with Disabilities Rules, 2017

15. Rules for Accessibility. - (1) Every establishment shall comply with the following standards relating to physical environment, transport and information and communication technology, namely :-

(a) standard for public buildings as specified in the Harmonised Guidelines and Space Standards for Barrier Free Built Environment for Persons With Disabilities and Elderly Persons as issued by the Government of India, Ministry of Urban Development in March, 2016;

(b) standard for Bus Body Code for transportation system as specified in the notification of the Government of India in the Ministry of Road Transport and Highways, vide number G.S.R. 895(E), dated the 20th September, 2016;

(c) Information and Communication Technology-

(i) website standard as specified in the guidelines for Indian Government websites, as adopted by Department of Administrative Reforms and Public Grievances, Government of India;

(ii) documents to be placed on websites shall be in Electronic Publication (ePUB) or Optical Character Reader (OCR) based pdf format:

Provided that the standard of accessibility in respect of other services and facilities shall be specified by the Central Government within a period of six months from the date of notification of these rules.

(2) The respective Ministries and Departments shall ensure compliance of the standards of accessibility specified under this rule through the concerned domain regulators or otherwise.

3. Accessible Information

Managers of the religious sites are encouraged to provide information and catalogues of individual religious sites in accessible formats such as large print, braille etc. The website or any online presence shall meet Web Content Accessibility Guidelines as mandated by Govt. of India. (www.w3.org/TR/WCAG20/)

The site managers may consider use of QR Codes at important locations to make them accessible to visitors with vision impairments. Mobile Applications that are friendly to all can greatly enhance accessibility of the religious buildings /sites especially to alert users with location of amenities, providing online links to all publication and reading materials such as information booklet, hymns, rituals and prayers etc. The site managers may consider making the information also available in large print, pictorial (wherever possible) and easy to read and understand formats.



Fig: 1. Installing QR code at important locations can enhance the accessibility to information and help independent mobility for devotees with visual impairment.

4. Parking

The designated accessible parking spaces that serve a religious building shall be located as near as possible to the main entrance that is accessible. An accessible route should be provided from designated parking space to the accessible entrance of the religious premises. Where there is no space available for parking, the management should provide passenger drop-off points for taxis/cars as near as possible to the main accessible entrance.

An appropriate tactile ground surface indicator (TGSi) from the reserved parking or passenger drop-off points should be provided to lead persons with vision impairment to the main entrance where no other clues indicate the path to the building

Key points

4.1 An accessible car parking should be served with an accessible route to connect with approach road and religious /worship building entrance.

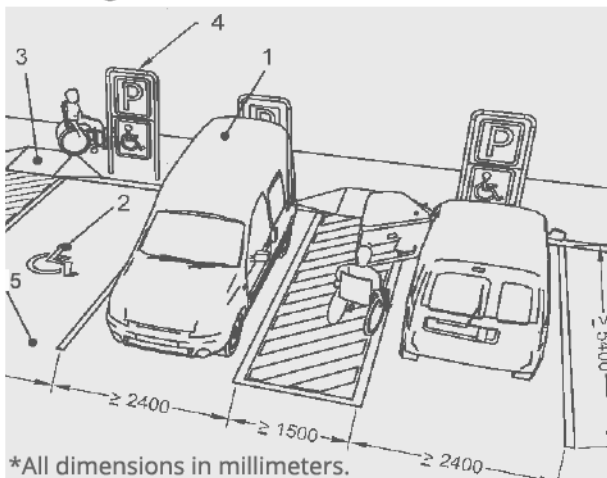
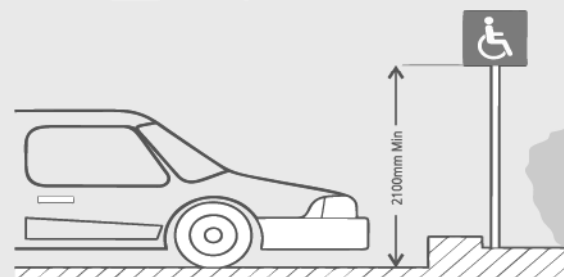

Fig: 2. Accessible Parking Specifications
 1. Minimum unobstructed height for vans 2600mm
 2. Symbol of accessibility
 3. Kerb Ramp
 4. Signage, including symbol of accessibility
 5. Firm ground



*All dimensions in millimeters.
 Fig: 3. Vertical sign at designated parking spaces

4.2 Location of car parking should preferably be within 30-50 m distance of the entrances of a place of worship.

4.3 Use universal symbol of accessibility for accessible car parking at approaches and entrances to car parking.

4.4 Install directional signage at strategic locations to direct and orient visitors.

4.5 A vertical sign for car parking to be displayed at a minimum height of 2100 mm from floor surface.

4.6 The minimum unobstructed height for modified or accessible vans is 2600 mm.

4.7 The minimum width of the parking space for a car should be 3900 mm (including transfer area of 1500 mm beside the car) and minimum length should be 5400 mm.

4.8 Minimum route of 1200 mm width to be provided for wheelchair users to pass behind parked vehicles.

4.9 Should have firm and levelled surfaces.

4.10 Vehicle drop-off areas should be minimum of 9000 mm in length, have a minimum width of 3600 mm and be served by kerb ramp.

4.11 Make accessible parking safe by providing sheltered drop-off area for taxis and vehicles, and also a sheltered pedestrian walkway connecting parking areas to entrance of the premises.

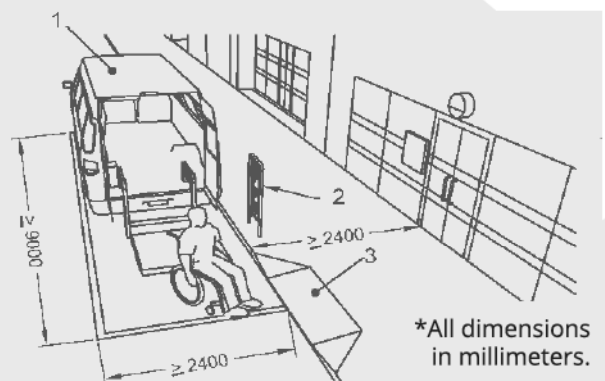

*All dimensions in millimeters.
 Fig: 4. Passenger drop off area beside sidewalk/footpath.
 1. Minimum unobstructed height - 2600 mm
 2. Signage, including symbol of accessibility
 3. Kerb ramp

5. Walkways/ Pathways

Once persons with reduced mobility alight from the vehicle, they must have unobstructed walkway passage to the entrance of the premises.

Key points

5.1 Provide smooth, hard and levelled surface suitable for walking and wheeling.

5.2 Pathway leading to religious building should have unobstructed width, not less than 1800 mm for two-way traffic, and 1200 mm for one-way traffic.

5.3 In case of space constraints, the same can be reduced to a minimum of 1500 mm for two-way traffic, provided that an appropriate turning space is given for every 25m.

5.4 Pathway should be well-lit with a minimum illumination of 100 lux.

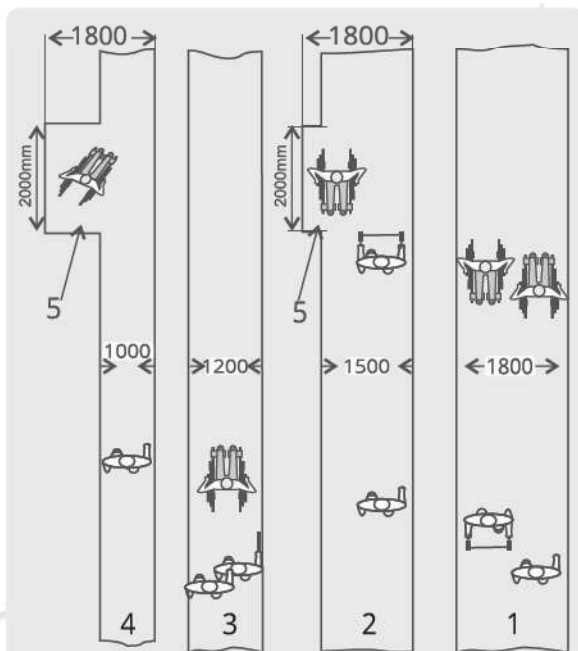

*All dimensions in millimeters.

Fig. 5. Surface width of the pathway leading towards worship place

Key:

1 and 2 For two-way traffic.

3 and 4 For one-way traffic.

5 Passing and turning space every 25m

(only acceptable for wheelchair users under exceptional circumstances)

6. Information Counter/ Reception Desk-

As India is full of diversity with plurality of languages, dialects, cultures, beliefs and traditions, it is crucial to have information in vernacular as well as main languages and should be in accessible format to benefit all people including those with disabilities.

Reception/Information counters should be distinctly visible from the entrance. Staff managing the counter should be trained and sensitized to effectively communicate and facilitate the visit of people with reduced mobility and those with disabilities including in sign language.

Alternative provisions such as audio version of print materials and Braille version of various worship and educational materials may also be provided at information desk /reception counter to orient devotees with disabilities.

Key points

6.1 Audio enhancement should be provided at the counters for information transmission to persons with hearing -impaired. Two - way mike system is beneficial for effective communication in high noisy areas.

6.2 A separate PRM desk should be available, preferably along with information counter for persons with reduced mobility, elderly and those with disabilities. PRM assistance should be located and clearly identified so that they are easily recognizable from a building entrance. Tactile guiding path can help in locating PRM desk for people who have vision impairment, therefore should be installed to orient visitors.

6.3 Tactile guiding path should lead from the entrance to the information counter and from the counter to the major circulation route.

6.4 Information counter for PRM assistance or those equipped with a separating security screen, should have at least one position fitted with a hearing enhancement system (for example induction loop system) to assist hearing-aid users and be clearly marked with the appropriate signage/ symbol to assist persons with hearing impaired.

6.5 Assistive technology such as loop hearing systems, audio orientation tools, interpretative videos or audio tours with captioning or sign language, wheelchairs etc. should be available.

6.6 An information panel or tactile pictographic map of the religious site near information counter should be provided at an accessible height for both seating and standing people.

6.7 The counter level shall be between 750 mm and 800 mm from the floor.

6.8 Clear knee space underneath the counter top shall be minimum 700 mm.

6.9 Staff and guides should be trained on use of assistive technology to help visitors with disabilities. The religious site should preferably provide access to WIFI to the visitors.

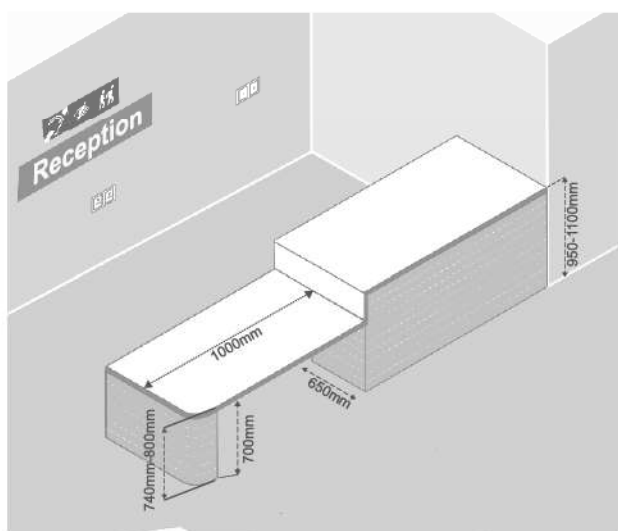

*All dimensions in millimeters.

Fig: 6. Suggested sample for Accessible Information Counter

7. Cloakroom / Shoe Rack

Attended cloakrooms are staffed rooms where bags/ luggage/shoes/ leather items and other personal belongings can be stored easily.

It's a common practice to remove footwear before entering a religious shrine and devotees have to park their footwear at a safe and earmarked counters/ stands. To provide equal and barrier free access to everyone, shoes countertops must be of different height.

Key points

7.1 Provide cloakroom facility at a location where it is easily recognized from the building entrance. It is preferable to locate the accessible shoe racks adjacent to ablution /cleaning space and be clearly sign posted.

7.2 Cloakroom desks should be accessible to persons with varying needs including wheelchair users.

7.3 Provide clear space no less than 900 mm x 1350 mm for wheelchair manoeuvrability towards visitor side.

7.4 The counter height should be between 750 mm- 800 mm from the floor. Clear knee space underneath should be minimum 700 mm.

7.5 Shelving or shoe racks should be no higher than 1200 mm to allow an easy forward reach over the working surface.

7.6 At least, a part of the cloakroom desk should be at a height to attend standing people, between 950 mm-1100 mm.

7.7 Provide sufficient lockers at heights between 450 mm to 900 mm with adequate space to accommodate visitor's belongings / bags. It should be easily operable by a person with reduced hand dexterity.

7.8 Locks and lockers should have clearly visible and embossed numbers that can be read by sight or touch.

7.8 Token receipt /ticket should have sufficient visual contrast along with tactile embossments.

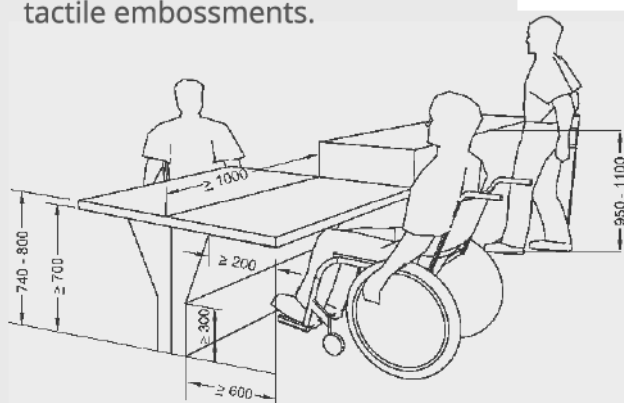

*All dimensions in millimeters.

Fig: 7. Specifications for Accessible Cloakroom

8. Accessible Washroom

As an integral feature of a religious building, washroom facilities should accommodate the range of visitors that will use the space. Although many persons with disabilities use toilet facilities independently, some may require assistance.

Persons with disabilities, wheelchair users, children and the elderly may benefit from a larger washroom with toilet facilities to maneuver wheelchair and assistive devices. The increased size of the toilet room is required to ensure that there is sufficient space to facilitate proper placement of a wheelchair or assistive devices to accommodate transfer onto the toilet seat. Minimum accessible features such as grab bars, mirrors, utilization space inside the washroom and wash basin at appropriate height should be provided on every floor of the buildings to assist users with reduced mobility. If this is not feasible in existing buildings, at least one toilet should be made accessible in each building preferably on ground floor.

Appropriate commode height and wider utilization space in front and on the side of commode seat facilitates convenient wheelchair transfer process. Also, amenities should be installed at convenient height along with provision of grab bars and handrails to assist persons with low muscular strength and reduced mobility.

Western commode can be a preferred choice over Indian style commode, as it reduces strain on user's knees and hips. However, provision of an accessible squat toilet along with grab bars and supporting handrails will cater to diverse range of population due to different cultural beliefs and customs. Directional signage for accessible toilet facilities should be indicated to orient persons with reduced mobility. Location of an accessible unisex toilet is crucial for persons with disabilities to use the facility without any inconvenience. It should be preferably located- near the entrance or changing room within a distance of not more than 30 meter, & should be visible directly from a public corridor.

Persons with visual impairments find

it convenient to use the toilets where internal dimensions, accessories and fixtures placements are standardized. A tactile layout of the toilet should be provided on the wall, outside the toilet near the latch side at a reachable height for a person sitting on a wheelchair.

Key Points:

8.1 The toilet door should be either an outward opening door or two-way opening door or a sliding type and should provide a clear opening width of at least 900 mm.

8.2 Internal dimension of an accessible toilet should be 2200 mm x 2000 mm.

8.3 One L-shape grab bar: 600 mm long horizontal and 700 mm long vertical should be mounted on the side wall, 200 mm-300 mm above the water closet.

8.4 WC height – 460 mm-480 mm from floor finish, however a higher toilet seat makes it easier to lower, stand, or transfer from a wheelchair/walker onto the toilet seat.

8.5 Grab bars should be mounted at a height between 700 mm and 800 mm from the floor. Option for height adjustment should be there.

8.6 An emergency call bell should be installed with a weatherproof push button for activating the alarm.

8.7 If accessible toilet is located outside the worship premise, it should be within 30 meters distance from the reception counter connected by an accessible route, so that persons with reduced mobility can access the toilet without any inconvenience.

8.8 Where plinth of toilet is not same as the floor, an accessible ramp of gradient 1:12 with handrails should be provided for convenient entry of persons using wheelchair or any other assistive devices.

8.9 For accessible squat toilet, minimum clear floor space of 1200 mm x 1500 mm is required.

8.10 Separate signage for female and male toilet in Braille and pictogram should be provided.

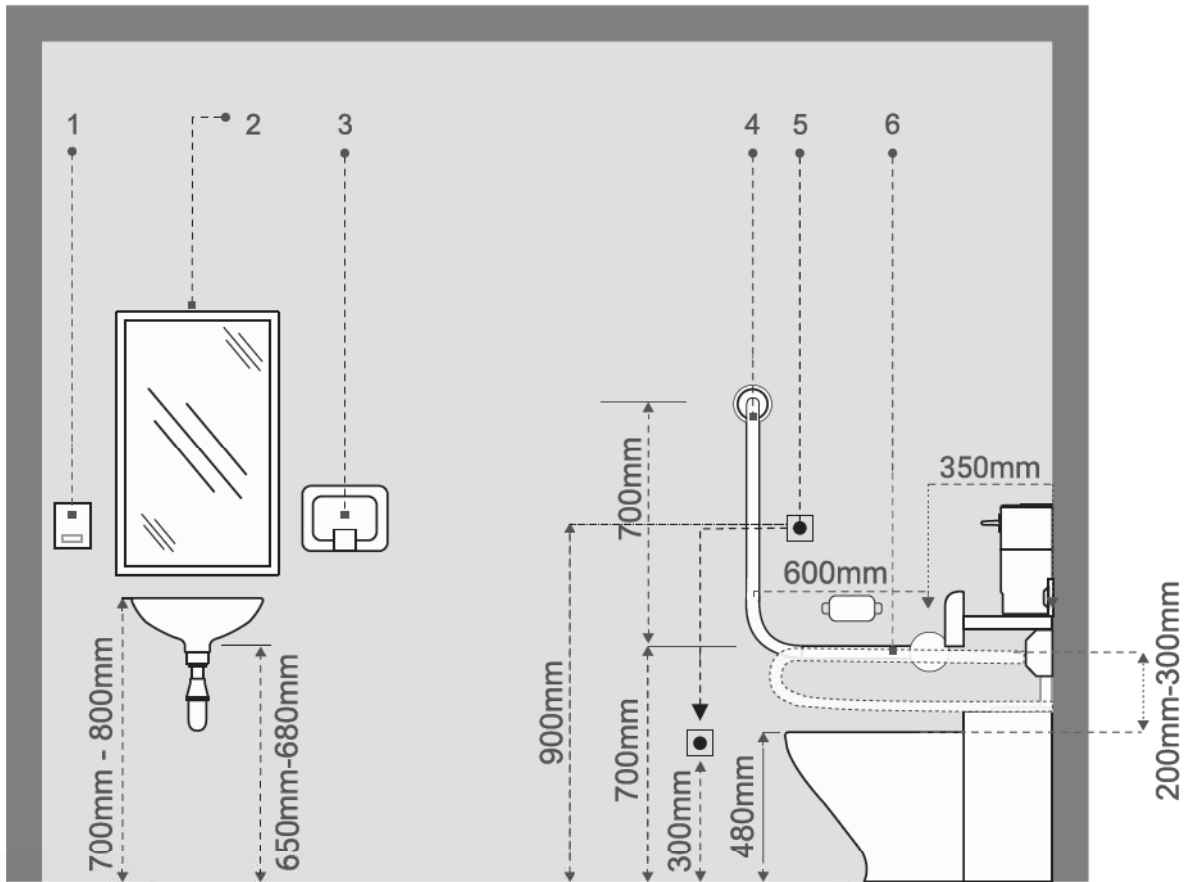

- 1 Soap Dispenser
- 2 Mirror
- 3 Towel
- 4 L-Shape Grab Bar
- 5 Emergency Call Button
- 6 Pull up Grab bar

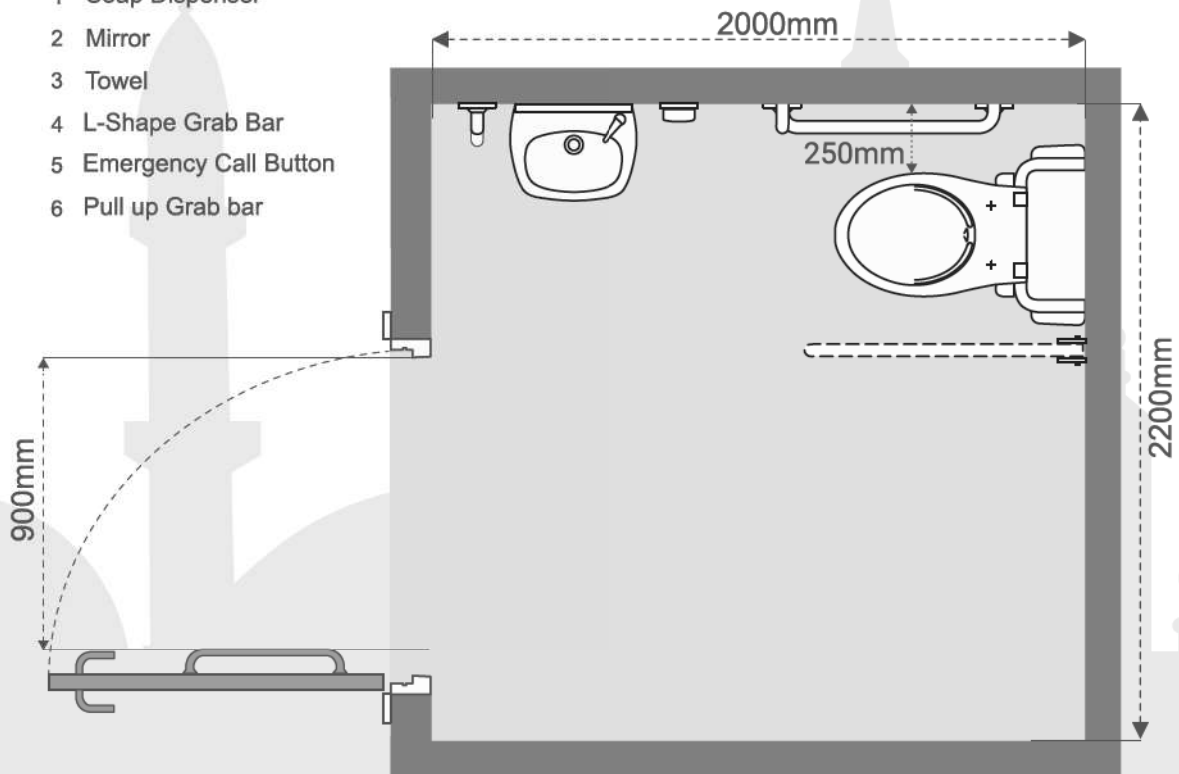

*All dimensions in millimeters.

Fig: 8. Accessible Washroom Specifications

9. Accessible Squat Toilet

As per local custom and beliefs, many people prefer squat toilet as they perceive it more hygienic because of the reason that squat pan surface does not directly come in skin contact. Therefore, a choice of layout suitable for Indian Squat Pan may also be considered as per following specifications. However accessible squat toilet will be in addition to the requirement of accessible toilet (western commode) and not a replacement.

Key Points:

9.1 Internal dimension should be minimum 1000 mm x 1500 mm.

9.2 Provision of L shaped grab bar on both side, which helps in assisting a person with ambulant disability to lower in to squatting position and then rise in to the standing.

9.3 Hand held spray/ faucet to be provided at height between 300 mm - 400mm.

9.4 Horizontal grab bar (placed at 500 mm) helps in providing stability while defecating and reaching for water and self cleaning etc.

9.5 Signage for male and female toilet in pictogram (Pictogram showing Indian squat Pan) should be provided.

9.6 Minimum clear door width should be 900 mm.

9.7 Water tap should be placed at 300 mm.

9.8 Lower level alarm at height 400 mm to be provided so that persons with disabilities can reach it during emergencies.

9.9 Door should open outside.

9.10 Flooring should be nonslip even when wet.

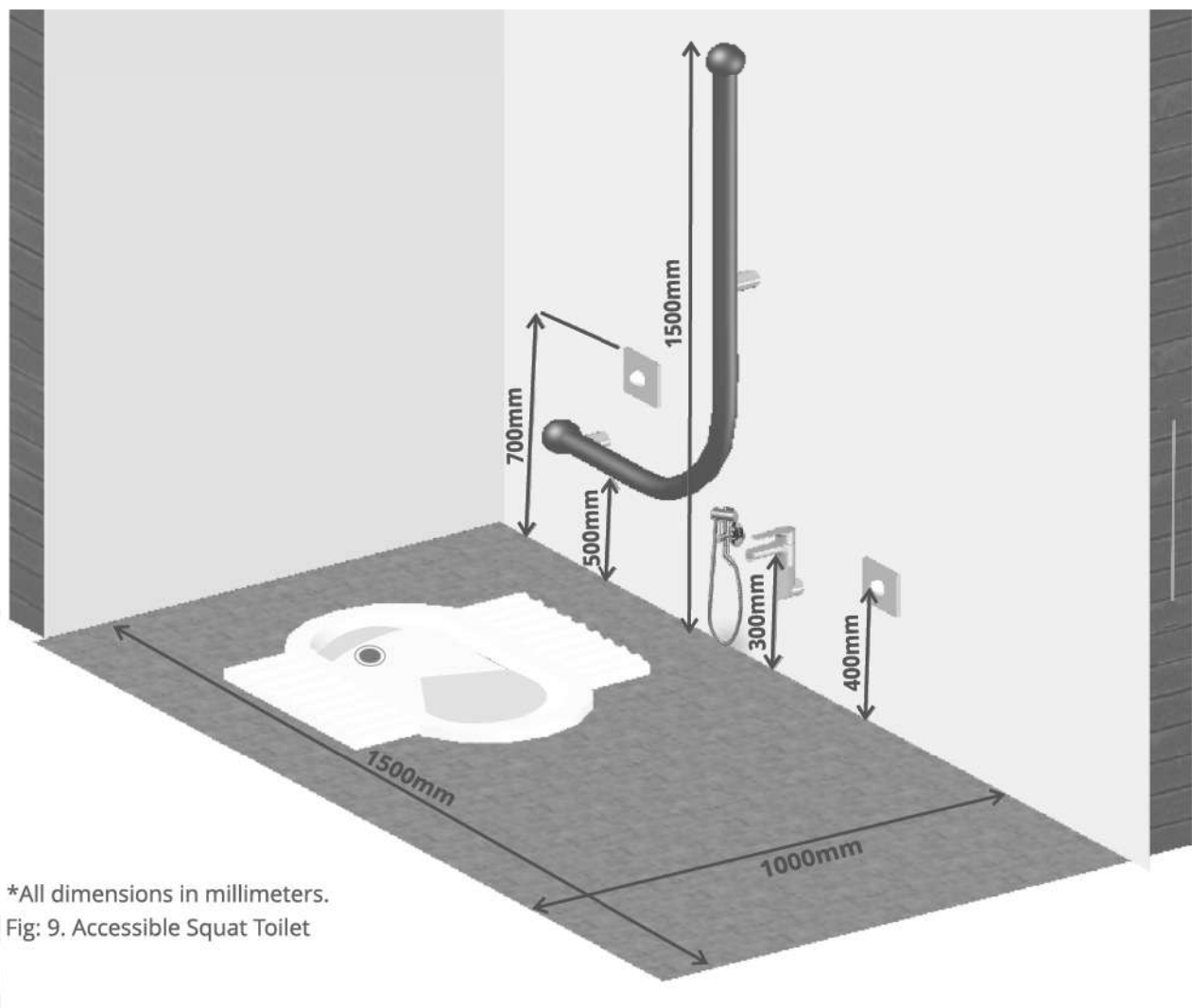

10. Urinals

Wheelchair users may be able to pull themselves to a standing position to use a urinal, or they might use a urinal from their wheelchair. When wall hung urinals are fitted in the washroom, it is recommended that at least one of these have its rim set at a height of 360 mm for wheelchair users and people with short stature, and at least one have its rim at a height of 500 mm for standing user or ambulant disabled. Both types of urinal should be equipped with vertical grab rails on both sides.

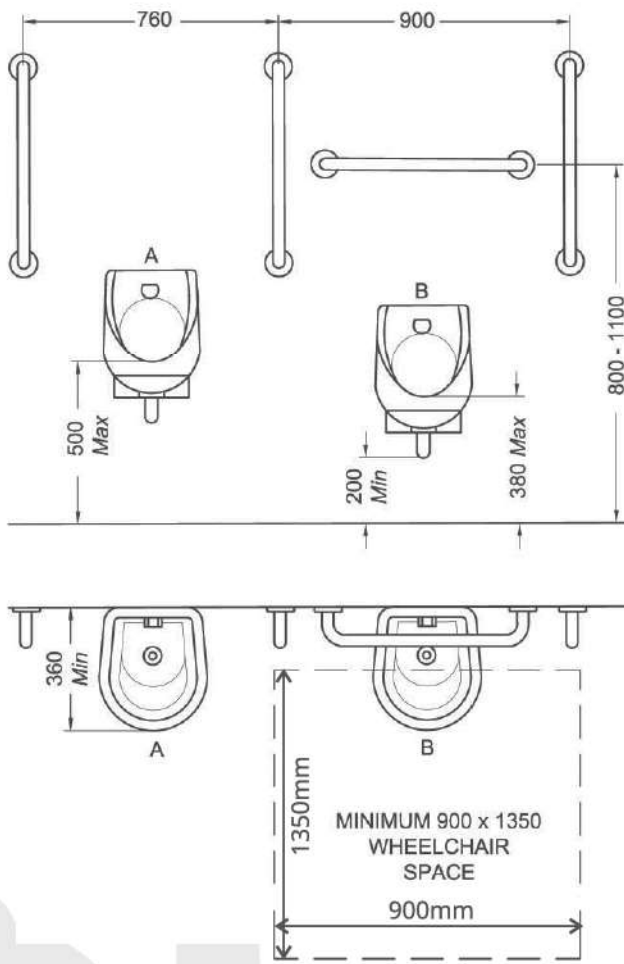

*All dimensions in millimeters.

Fig: 10. Accessible Urinal

A- Suitable For Ambulant Disabled People

B- Suitable For Wheelchair Users

11. Ablution/Cleaning Space

This is a place for ritual of holy washing (such as wuzu, shuddhi, etc.) which is considered mandatory before the devotees begin their prayer. This area should be wheelchair accessible and should provide facilities that meets the specific needs of people with disabilities.

Key points

11.1 Signage indicating the cleaning /ablution area should be installed at strategic locations to orient visitors.

11.2 Provide anti-slippery surface at waing or ablution point that allows water to drain underneath.

11.3 The water drainage channel should be covered with a mesh for safety. The slots in gratings should not be more than 12 mm to prevent wheelchair casters getting wedged into wider openings.

11.4 At least one water sprout outlet or tap should be 900 mm above the floor and have clear knee space of 700 mm high, 480 mm deep and toe spaces of 300 mm underneath and be signposted as accessible.

11.5 The water sprout or tap should be lever or sensor operated to aid persons with weak hand dexterity. Hot and cold water taps should be identifiable by both color and tactile markings.

11.6 Provision of water faucet should be made that could be pulled out closer to user's body. The water faucet / spray hose could also be used to clean wheelchair wheels.

11.7 Provision of mats, dryers could be considered to dry wet hands, feet's and mobility devices etc.

11.8 Provide a shelf for the user to keep personal belongings such as shoes, bags clothes etc.

12. Accessible Changing Room

Showers and changing rooms at religious places are used by people for purification purpose. All changing areas must be designed in a way that people with disabilities can use them easily. This should be preferably located adjacent to ablution space and cloakroom area.

Key points

12.1 The shower /changing area should have level entry, and have no fixed elements that prevent front and side access.

12.2 A fixed bench should be set at a height of 450 mm to 480 mm above floor level.

12.3 The bench should be no less than 500 mm wide, 2000 mm in length and be provided with a support grab bar at a height of 700 mm from the floor level.

12.4 Provide clear space of 1500 mm x 1500 mm besides bench for wheelchair manoeuvrability.

12.5 Install cloth hooks above floor level at different heights ranging from 900 mm - 1400 mm.

12.6 Ensure non-skid floor surface and color and tonal contrast of other furnishings.

12.7 Install an alarm/call bell or switch at suitable height.

12.8 Direct access should be provided to the shower area from the changing room.

12.9 Some visitors may prefer the privacy of an individual cubicle and, wherever possible, the same should be provided. Where appropriate, these individual cubicles should be fitted with support facilities such as handrails or grab bars.

12.10 Changing room should have a min area of 2200 mm x 2000 mm.

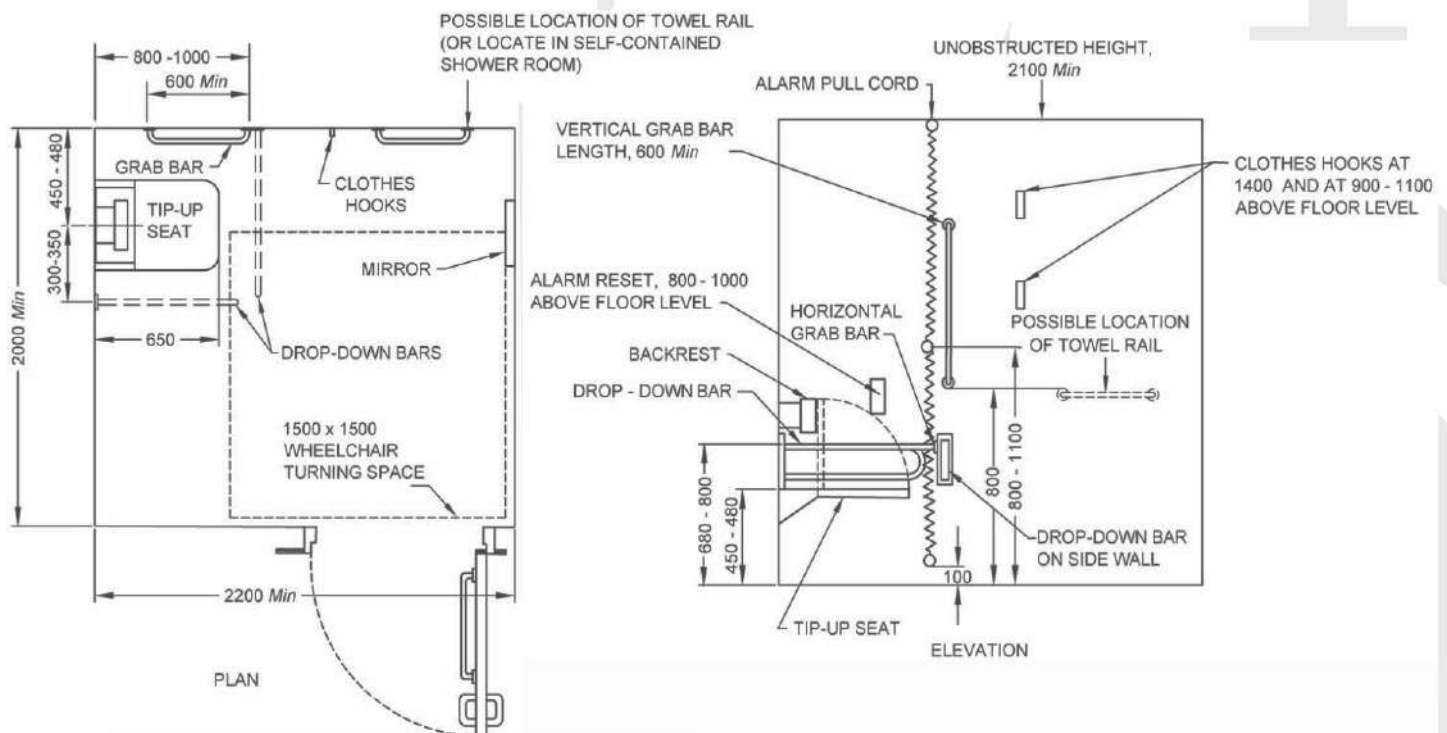

*All dimensions in millimeters.

Fig: 11. Accessible Changing Room For Individual Use

13. Entrance

At least, one entrance to a religious building should always be accessible, preferably the principal entrance which connects with the approach road.

Entrance should be in contrasting color with surroundings and have tactile marking in front of entrance to help persons with visual impairment to locate the facilities. The International Symbol of Accessibility must be displayed at all accessible entrances.

All major entrances should be wide enough for unobstructed entry of visiting traffic. The doors should preferably open by sliding to the side, rather than opening outward, to allow unobstructed access for people using wheelchairs and walkers etc.

14. Doors

The minimum clear opening of doorways should be 900 mm. In case, the door has two independently operated door leaves, at least one active leaf should provide clearing opening width of 900 mm. Doors, latches, pulls and locks must be easy to operate with one hand, and should not require tight grasping, pinching and twisting of the hand and wrist.

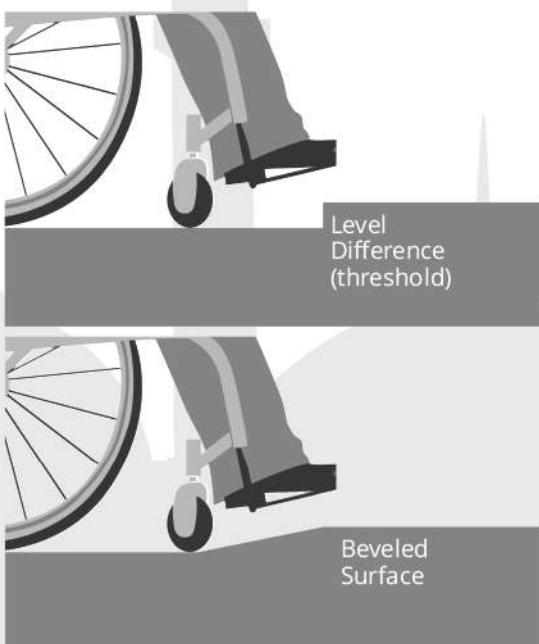

*All dimensions in millimeters.

Fig: 12. Accessible Door Specifications

Thresholds at any connecting doors must not exceed height more than 12 mm, and floor-level changes should be bevelled (sloped). Older houses of worship may have high thresholds which become obstacles for wheelchair users. Higher thresholds can be removed or modified. In some cases, problems can be resolved by raising the adjacent walk or finished floor to meet the requirements.

Many historic religious places may have heavy artistic doors, which may impede independent access, although they may have significant features which should not be aesthetically compromised. Modifying or replacing some of the hardware can make them more user-friendly.

Key Points

14.1 Hardware for closet doors, drawer pulls, etc., should be of the simple 'D' type.

14.2 Use lever type fixtures instead of circular or spherical knobs.

14.3 Door hardware should be mounted at a height of 850 mm to 1000 mm from the floor.

14.4 Force required to operate the door should not be more than 22 N.

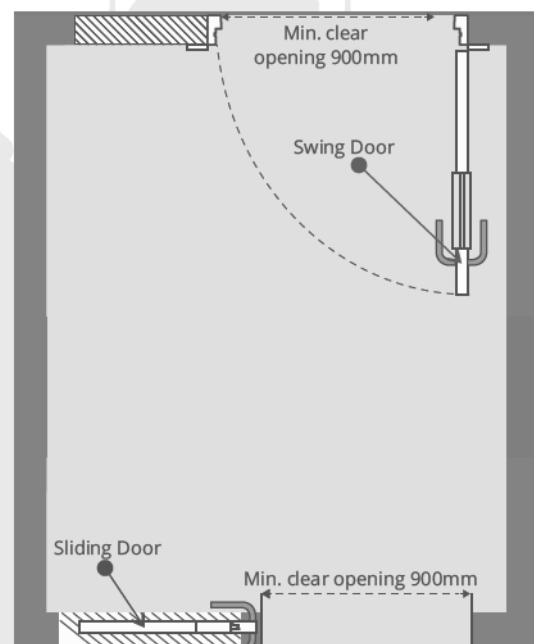

*All dimensions in millimeters.

Fig: 13. Minimum clear opening for doors

15. Circulation Area

Circulation area within premises or leading to different sections within premises should be sufficiently wide with suitable passing spaces to accommodate visitors who are likely to be carrying bags, religious offerings or using assistive devices including wheelchairs. For religious buildings, width of the corridor should be extra-large to accommodate higher footfall. In all cases, corridors should be left unobstructed and surface should be anti-skid in nature. Items such as water cooler, radiators and fire extinguishers etc. should ideally be recessed, so that they do not project into the clear width of the corridor.

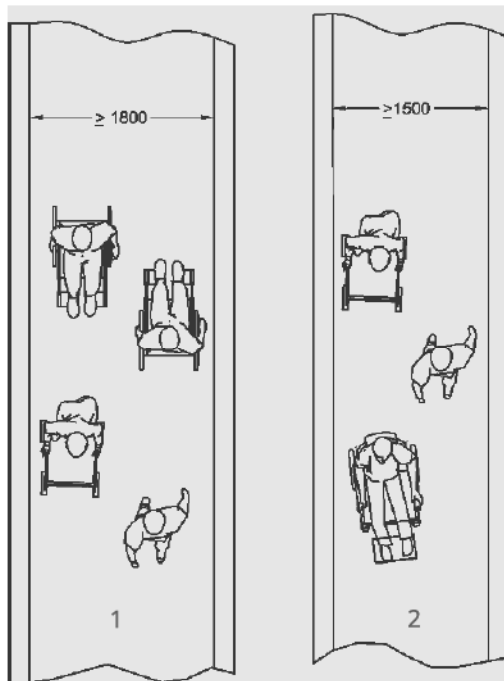

*All dimensions in millimeters.

Fig: 14. Preferred Corridor Width

Key

1. Preferred corridor width for two wheelchairs to pass.
2. Preferred corridor width for one wheelchair to pass.

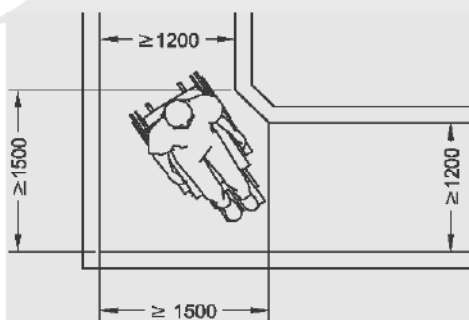

*All dimensions in millimeters.

Fig: 15. Manoeuvring space required for a wheelchair to make a 90° turn

16. Seating Benches

Places of worship can have long corridors or open areas for meditation and prayer. Elderly devotees, pregnant women and persons with limited strength and endurance may require handrail support and/or resting places in long corridors or meditation zone.

In extended length corridors of 50 m or more, consideration should be given to the provision of a bench or other seating, located at intermediate points along the corridor for the elderly and others with visual impairment and reduced mobility.

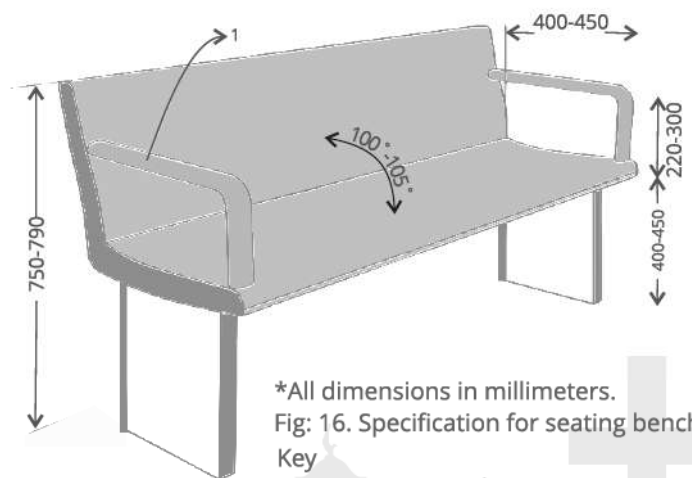

*All dimensions in millimeters.

Fig: 16. Specification for seating bench

Key

1. Armrest omitted on some benches to allow lateral transfer

17. Tactile Ground Surface Indicators (TGSIs)

A consistent and continuous guiding system has great impact on the personal mobility of persons with visual impairment when moving around. Different means of orientation should be provided to help devotees with visual impairment navigate easily. Where the pathway leads to a dangerous situation or change of level, tactile warning should be used.

Types of TGSIs

17.1 Tactile Directional - Used for providing directions and orientation to persons with visual impairment and should preferably be installed in open areas such as lobby, entrance hall, waiting room, reception area and areas leading to accessible washroom, lift and parking, etc.

17.2 Tactile Warning- are textured surface features applied to the walking surfaces that are intended to function much like a stop sign. They alert persons with vision impaired about change in level or direction in their line of travel; indicating that they should stop to determine the nature of the hazard before proceeding further. Warning blocks should be placed 300 mm at the beginning and end of the ramps and stairs, at landings and entrance to any door. It should be also installed before the information counter, reception desk etc. to alert users about the specific facilities.

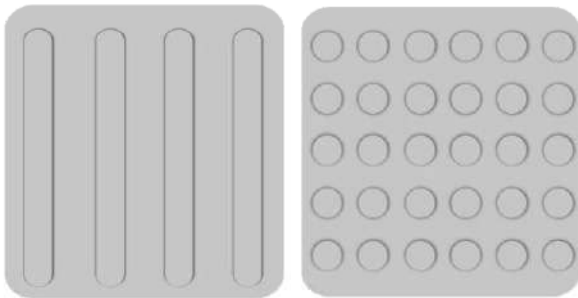

Fig: 17. Directional Tactile Fig: 18. Warning Tactile

18. Ramp

Ramps provide easier access, not only for persons in wheelchairs and for those with reduced mobility but also for visitors pushing strollers, mothers with baby or a person carrying devotional offerings. Level changes at entrance, in the circulation area or within the premises of a religious building should be accessible. Where space allows, ramps are good means to achieve accessibility.

At least one entrance preferably the principal entrance to a religious building should always be accessible, If stairs hinder the access in old religious buildings, a smooth gradient ramp should be provided to ensure access to the building for wheelchair users.

Key Points

18.1 Ramp should be either straight run, 90 degrees turn or switch back. Curved and circular ramps are not recommended.

18.2 Slope of ramp should be smooth, preferably in the range between 1:12 - 1: 20, depending on the level difference it addresses. (see table below)

18.3 Landings should be provided for resting, manoeuvring and avoiding excessive speed.

18.4 Landings should be provided at least every 5 meters of the ramp length depending on the length of the ramp.

18.5 Landing should also be provided at every change of the direction and at the beginning and end of the ramp.

18.6 The surface of the ramp should be anti-skid, hard, easy-to-maintain and which does not allow accumulation of water.

18.7 Handrails should be provided on both sides and along the full length of the ramps.

18.8 Handrails should be in a color that contrasts with the floor and the wall to help people with visual impairments. The end of handrails can also be used to provide information in Braille.

18.9 Textural markings at the beginning and end of the ramp are recommended to orient persons with low vision.

18.10 Railings should merge well with the architectural style of the building, or replicate the traditional and ornamental design of the building.

Level Difference	Min gradient of Ramp	Ramp width	Handrail on both sides	Comments
>150 <300	1:12	1200 mm	✓	
>300 <750	1:12	1500 mm	✓	Landing every 5m of ramp run.
>750 <3000	1:15	1800 mm	✓	Landing every 9m of ramp run.
>3000	1:20	1800 mm	✓	Landing every 9m of ramp run.

Table: 1 Requirements for Ramp

19. Stairs

Uniform stairs are an important means to address level differences in a building and this need to be improved from the perspectives of accessibility for a wide range of users. Many ambulant disabled may prefer a shorter staircase to a longer ramp, provided it has good handrails for support and protection. In new proposed religious buildings, stairs should always be supplemented by lift to provide connectivity with other vertical floors.

Key Points

19.1 Stairs should be well lit without glare, and should provide a landing at the top and the bottom.

19.2 Should have no doors that swing into and obstruct the top or bottom landings.

19.3 Handrails should be provided on both sides along the full stair run, including on landings. Two level handrails to address needs of visitors of different heights should be provided. First handrail at a height of 650 mm - 750 mm from the floor and second at 850 mm - 950 mm from the floor is recommended.

19.4 Handrails should be in a color that contrasts with the floor and the wall to help devotees with visual impairments.

19.5 Handrails should extend horizontally for a distance not less than 300 mm beyond top and bottom of the stairs as shown in figure.

19.6 Should have detectable tactile warnings at the top and bottom of the staircase.

19.7 Avoid curved stairways. Provide landing after each 10 steps with intermittent rest or landing area.

19.8 Tread and riser should be 300 mm deep and 150 mm high.

19.9 Special consideration should be given for choosing materials for the surface finish of the stairs. It should be firm and slip resistant as the surfaces are likely to become wet because of carriage of ritual offerings & wet feet of the devotees.

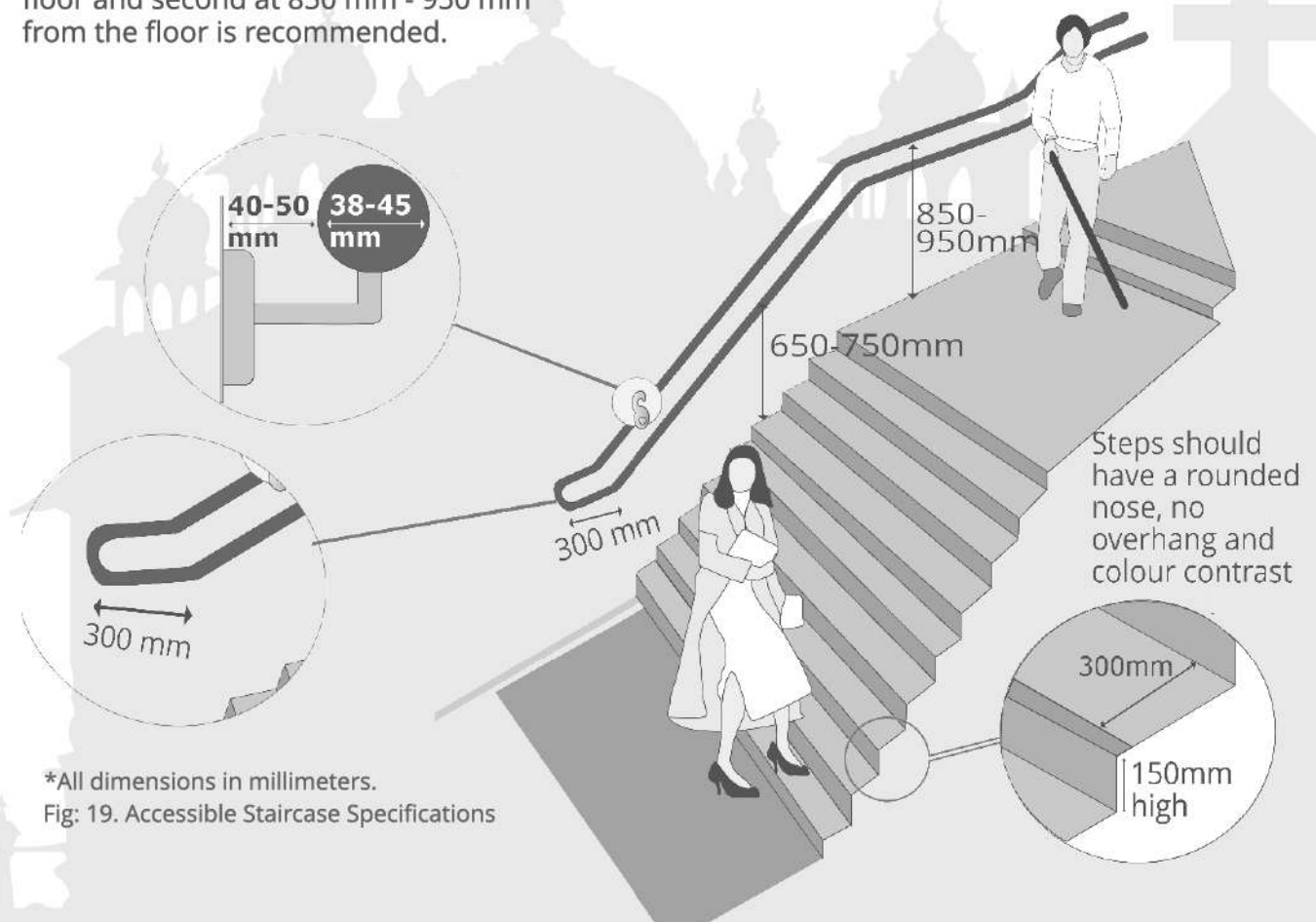

20. Lift

A carefully designed lift contributes greatly to the accessibility of a religious building, particularly for people with reduced mobility and wheelchair users. An accessible lift should serve all the floors and its location should be clearly indicated and recognizable from the building entrance. The arrival at each floor should be indicated by both the optical and acoustic means to alert visitors with visual and hearing impairments. Number, type, size and speed of lift should be determined by traffic analysis and visitors load to the religious building, and should allow adequate flexibility of the solution to accommodate future changes. The design and internal layout of lift needs to take into account all types of disabilities, with a clear and precise layout, sufficient internal space and high-quality voice communication with an alarm (two-way communication system) permanently connected to a manned security point. The internal space should accommodate minimum one attendant to assist wheelchair users.

Essential accessibility features such as grab bars, minimum door dimension, good color contrast should be incorporated to assist mobility of persons with disabilities.

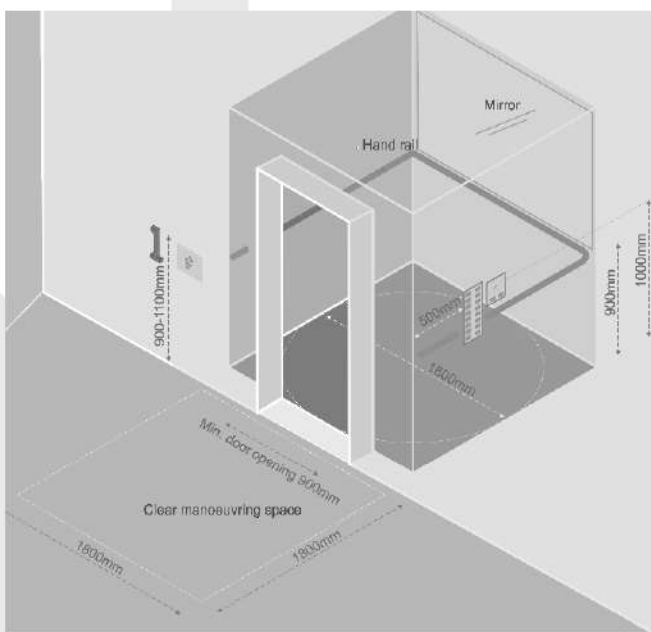

*All dimensions in millimeters.

Fig: 20. Accessible Lift Specifications

Key Points

20.1 The minimum size of lift shall be 1500mm wide by 1500 mm deep to allow easy maneuverability of wheelchair users.

20.2 The clear opening of lift door should be minimum 900 mm. The lift door should be in contrasting color with adjoining wall.

20.3 The gap between the lift door and building floor shall not be more than 12mm to ensure independent access for wheelchair.

20.4 Lift should be equipped with handrails mounted at a height of 900mm from the floor level, and be fixed on both sides and at the rear of the lift.

20.5 The call button should be located outside the lift at a height in between 800 mm and 1000 mm.

20.6 Lift control panel shall be placed at a height between 900 mm -1100 mm from the floor level. Touch control panels should not be used as they are not accessible to persons with visual impairment.

20.7 The control panel should have buttons with Braille/raised letters and in sharp contrast with the background to aid people with visual impairments.

21. Vertical and Inclined Lifting Platforms

In old religious buildings with heritage value, where design limitations make it impracticable to provide an accessible lift or a ramp in an existing building, vertical or inclined lifting platforms should be provided as a reasonable alternative for vertical circulation within the building. These are special passenger elevating devices for persons with disabilities. These may have either vertical or an inclined movement. These shall be able to be used safely, independently and also with an accompanying person. All control devices shall also be accessible and usable for powered wheelchair and walking aids users. If driving, guiding or lifting mechanisms present hazards at the sides of a platform, the mechanisms shall be guarded to protect the users. The guarding shall be smooth, hard and continuous. The minimum width of the platform lift shall be 1100 mm and the minimum length shall be 1400 mm for the use of manual and powered wheelchairs with assistance. In existing buildings of minor public importance and with few visitors, where sufficient space is not available, other dimensions may be considered, for example 900 mm x 1250 mm.

Vertical Lifting Platforms (see Fig. 21) for maximum level changes of 2500 mm, vertical lifting platforms may be installed. For level changes of more than 1200 mm, the lift shall be placed in a closed structure with doors at different accessible levels. Vertical lifting platforms may have a variety of openings for entry and exit.

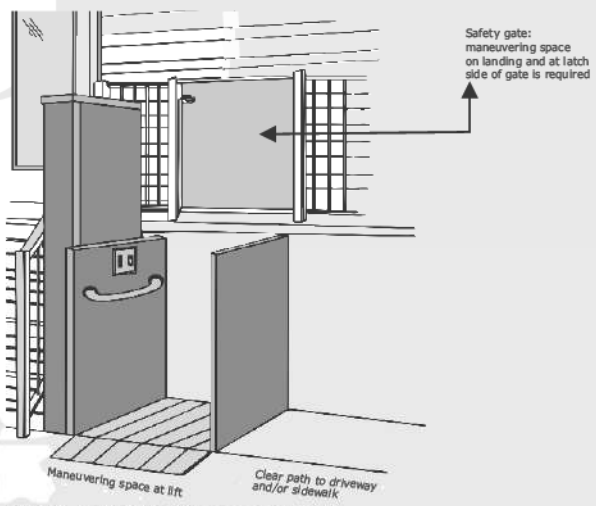

Fig: 21. Platform lift components

Inclined Lifting Platforms (see Fig. 22) Inclined lifting platforms consist of three elements; a railing, an electric generator and a moving platform. The operating system of the lift may be lateral or suspended. Inclined lifting platforms may be installed along the stair wall as long as they do not obstruct the required width of the exit. The platform may be folded when not in use. Inclined lifting platforms may be installed on all types of stairs including switch back stairs, that is, those with a rotation of 180° and spiral staircases. Inclined lifting platforms are usually used to connect one or more floors or to overcome split levels in existing buildings.

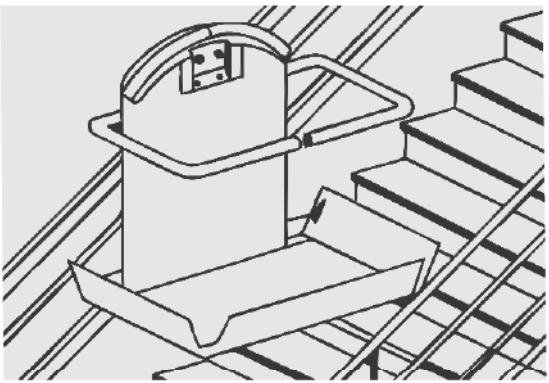

Fig: 22. Platform lift components

22. The Worship Space

Group worship or congregational prayer is a significant aspect of religious life for people of all religions. If group capacity for offering prayers is large, the wheelchair space should be provided in more than one place. If standing to offer prayer or chant is a regular part of worship, this should be taken into account when considering sight lines for wheelchair users. In many worship places, wheelchair space can be created by removing a few benches in the front, middle or back; another alternative is to replace some or all of the fixed seating with moveable customized chairs which can accommodate wheelchair users. Consideration should be given not to alter the aesthetics and religious or heritage value of the worship space.

Capacity of seating in worship space/prayer area	Number of required wheelchair locations
4-25	1
26-50	2
51-300	4
301-500	6
500 above..	More than 6

Table: 2 Allocation of wheelchair seating in worship area

23. Access to Rituals

At religious places, devotees also perform certain rituals associated with each religion or place of worship. Therefore, it should be ensured that people with reduced mobility are also able to access all rituals and associated activities with ease and safety.

24. Accessible Counters/ Shops

The shops/ counters selling items needed to perform rituals should:

(a) Be low height (750-800 mm) with knee clearance of 680 mm. The route leading such counters should be at least 1200 mm wide, for one way traffic, provided appropriate turning space is there for every 25 m.

(b) The floor surface should be stable, firm, level and slip-resistant, preferably of matt finish and should not have any projections, drops, or unexpected variation in level that may impede the easy access of persons with disabilities.

© For people with low vision, lines of brightly coloured fluorescent tape may be placed on the floor surface to assist mobility in poor lighted areas. Innovative approaches such as directional tactile foot prints may be helpful to guide devotee visitors.

25. Public Address System

A well-managed public address system to guide the devotees performing rituals is useful. It also helps in control the flow of visitors and pass on instructions, in case of emergency and to avoid congestion and stampede. It is suggested to provide digital information panels where the information announced can be displayed in Regional language and English for the benefit of devotees with hearing impairment.

26. Staff Training

Marshals/ volunteers, sevadars, providing assistance to persons with disabilities should receive regular sensitization training on disability etiquette how to address the specific needs of persons with disabilities & those in need of assistance at counters.

27. Transportation/ Mobility

Where the existing religious place is situated in hilly areas or at steep heights with no accessible alternate possible due to space or technological constraints, the religious place committees must consider accessible traditional mobility aids like palkhi/doli for elderly and persons with disabilities to negotiate the difficult terrain to reach the religious site which may be on minimal charges set up by the religious committee. Where possible, battery vehicle /cart to ferry persons with disabilities could be provided.

28. Access to Langar / Bhandara / Prasad

Langar is the free communal kitchen service that is part of every single Gurudwara (worship place for the Sikhs) in the world. Usually, langar services are provided round the clock for everyone without any discrimination. Langars also take place at Dargah and temples on special occasions / days.

Key Points

28.1 Route leading to Langar halls should be accessible for everyone. Please refer section 5; pathways specification compliance.

28.2 The surface of langar hall should be anti-skid. Where, carpets are used within Langar hall area or within the premise of Gurudwara , they shall-

28.3 Not be deeper than 12 mm, Should be securely fixed and have firm cushion and

28.6 Exposed edges of carpets should be fastened to floor surface and trimmed along the entire length of the exposed edge.

28.7 Between two rows of Langar, minimum 900 mm aisle space should be provided for wheelchair mobility for people to pass through.

28.8 Since elderly and persons with reduced mobility may have trouble sitting on floors for eating langar food, provision for accessible desks/ table with underneath knee space should be provided in an appropriate space. These seating benches should be located evenly at the corner for easy access.

28.9 Where possible, assistive devices such as modified swivel spoon, special needs utensils should be made available for those who has poor hand dexterity and coordination difficulties.

28.10 Wayfinding signage to indicate location of Langar hall should be installed at strategic locations and to be displayed at eye level.

29. Access to Sanctum Sanctorum/ Deity Visual Access

Equal access to sanctum sanctorum or a place of deity is also crucial for inclusive worship. It is a usual practice to keep the deity at a height or at a place, which is not in the line of view for such devotees. Therefore, spaces should be identified from where people with short stature or those on wheelchairs get the direct visual access.

If standing to sing or pray is regular part of worship, this should be taken in to account when considering sight lines for wheelchair users. In many worship spaces, it may be relatively easy to provide room for wheelchair users by removing a few benches/pews in the front, middle or back. If the worship space has theater seating and a sloping floor, it may be possible to remove existing fixed seats so that wheelchair users can roll on to a level seating platform.

30. Including hearing impaired devotees

Provide hearing assistance devices for the persons with hearing impairment and consistently use microphones so that their hearing devices pick up all sound. If reinforced sound is not available, encourage people who hearing impaired to sit in the front rows. Speak and sing directly toward them.

31. Accessible Seating

Accessible seating locations, in addition to the fixed seating, should be provided at various places to ensure that persons with disabilities can sit with other family members or friends.

Where seating capacity exceeds more than 100, wheelchair spaces should be provided in more than one location. In existing building where retrofitting or alteration in structure is not technically feasible, wheelchair space may be clustered together as shown in figure below.

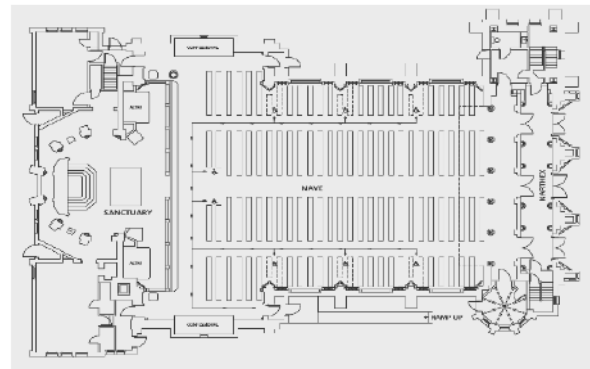

Fig: 23. Layout of Sanctuary with wheelchair seating plans (Source:- Unitarian Universalist Association)

32. Religious displays, exhibition areas and galleries

People with disabilities should easily access all displays or exhibits.

Key Points

32.1 Aisle spaces between exhibits or study areas should be at least 900 mm.

32.2 Exhibits should be mounted so that a person using a wheelchair can look at the exhibit easily from a seated position. Where exhibits are displayed in horizontal or inclined cases, they should be mounted no higher than 900 mm and wherever possible, include knee space below at 700 mm high to allow a direct approach by a person using a mobility aid (e.g., to approach book displays or small object displays).

32.3 For persons with visual disabilities, tactile exhibits should be available (e.g., sculptural pieces), with nearby information printed in large print text, braille, or provided on an audiotape.

33. Signage and Wayfinding

Signage is required in all worship spaces as well as the building area to provide direction and information to the devotees with disabilities to help them access all public areas at a religious place without any difficulty.

Signage has primarily three functions
 (I) Informative - To provide information,
 (II) Directional - To give directions towards facility or services,
 (III) Locational- To identify locations.

The "International Symbol of Accessibility" should be used to identify special amenities, such as accessible parking, accessible entrances, accessible washrooms, elevators, evacuation and refuge areas, rest rooms, ablution space, and bathing facilities etc.

Key Points

33.1 The design of signs should allow for contrasting colors, serif-free text, simple and consistent use of symbols and the provision of tactile information.

33.2 Signs need to be carefully located, so as to help visitors throughout their journey by providing information at junctions or in long passageways. Place directional signs at all major intersections and other signs in consistent locations. Place maps, including "you are here" maps, and large font informational handouts at reception areas and at strategic location of the religious building help greatly in orientation in new a place.

33.3 Signage placed at walls within reachable range needs to be tactile/Braille enabled.

33.4 Consider signs in pictograms along with text in English and vernacular language.

33.5 While planning a system of installing signage for information, it is crucial to ensure continuity and consistency to avoid confusion.

Fig: 24. International Symbol of Accessibility

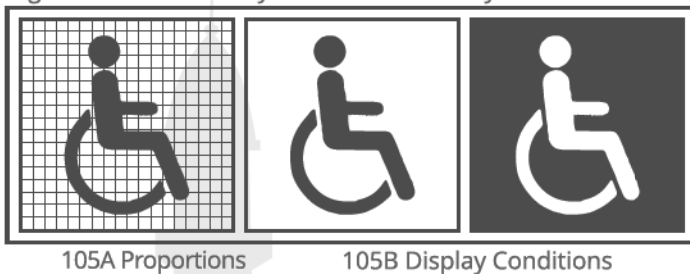

Fig: 25. Accessible Ramp



Fig: 26. Accessible Lift



Fig: 27. Human Assistance



Fig: 28. Accessible Unisex Toilet



Fig: 29. Accessible Male Toilet



Fig: 30. Accessible Female Toilet



Fig: 31. Unisex Changing Room



Fig: 32. Vision Impaired



Fig: 33. Hearing Loop



Fig: 34. Ablution/Cleaning Space



Fig: 35. Prayer Space



Fig: 36. Accessible Emergency Route

24. Safe Egress and Evacuation for People with Disabilities

Ensuring safe egress in an emergency situation at a religious building is a vital issue requiring consideration of a broad range of factors, including the design and usage of a building, the training of staff and the provision of appropriate equipment and facilities. Elderly, Persons with reduced mobility and varying disabilities are at greater risk during fire and any other emergencies as they may need assistance in evacuation. Therefore, it is important to ensure that a comprehensive evacuation plan and operational strategies are in place in case of a fire or other emergency.

Key Points

24.1 Simple floor plans of the building showing the locations and routes to circulation paths and worship space should be available and displayed prominently near the building entrance and at other appropriate locations to guide visitors with reduced mobility.

24.2 On request, people with reduced mobility should be provided with some form of written directions, a pictorial brochure and a map showing all directional signs for circulation paths.

24.3 People with reduced mobility must be able to travel to the pre-identified 'area of refuge' with or without any assistance. There should be no level difference within the building up to the area of refuge. However, if any level differences exist in the circulation path and there are constraints of space, conservation or architecture, accessible evacuation devices may be used such as emergency evacuation chair. Training and an understanding for evacuation methods are important aspects of the planning process.

24.4 Protocols for evacuation of persons with visual, hearing and mobility impairments must be developed and stakeholders trained and sensitized through frequent mock-drills.

24.5 Appropriate visual, tactile, and/or Braille signage in appropriate locations conforming to the approved standards should be installed in the premises.

24.6 People with hearing impairments will miss audio alarms and voice announcements that warn of danger and the need to evacuate. It is advisable to use audio-visual notification system so as to alert persons with hearing and visual impairments. It is advisable to install emergency alarm both audio (hooter type) and visual (flashing bulb) on each floor /level at strategic locations

24.7 Installation of scrolling digital message / display boards are vital to communicating safety messages & emergency announcements too.

24.8 Each exit door shall be marked with a sign "EXIT" that is clearly visible and properly located.

24.9 Locations of exit signs should be specified by pictorial signage. These signs must be placed above or adjacent to the exit doors and big enough to be visible clearly.

24.10 At least 30% of exit routes should be made accessible and duly sign posted. Signage plan must guide people with reduced mobility to nearest accessible route and refuge areas.

24.11 Every exit, exit passageway and exit discharge shall be continuously maintained free of all obstructions or impediments to full use in the case of fire or other emergency.

24.12 Floor surface should provide sufficient grip to prevent slipping. Adequate lighting and ventilation to be provided.

24.13 Unless otherwise specified, all the exits and exit passageways to exit discharge shall have a clear ceiling height of at least 2.4 m. However, the height of exit door shall be at least 2.0m.

24.14 Every building having human occupancy shall be provided with exits sufficient to permit safe egress of occupants, in case of fire or other emergency.

24.15 To avoid stampede like situations, it is recommended to regulate the flow of visitors movement inside the religious building. This being an assembly area without fixed seating, at any given time the maximum occupancy load should not exceed 0.65m² per person.

24.16 Display boards indicating what to do during emergencies should be installed at strategic locations for awareness.

24.17 Sensitization sessions / mock drills should be organized for staff members to enable them to assist persons with reduced mobility during situations of emergency.

24.18 Helpline numbers of Fire Safety, Disaster and other emergencies should be provided at information panel and other strategic locations.

24.19 The religious building managers shall be required to display, limiting occupant load details positioned in a conspicuous place near the entrance to avoid possible overcrowding. The display shall preferably be engraved on a metal plate of not less than 300mm × 200mm, with letters of height and width not less than 50 mm, with detail of occupancy, area and occupancy load. (see fig below)

MAXIMUM OCCUPANCY

**____ PERSONS PERMITTED
WITHIN THIS SPACE/ROOM**

IT IS CONFIRMED THAT THE FIRE EXITS ARE PLANNED FOR EGRESS OF THE OCCUPANCY AS MENTIONED ABOVE AND OCCUPANCY MORE THAN THE ABOVE IS NOT PERMITTED IN THE SPACE/ROOM AS FOLLOWS :

SPACE/ROOM DETAIL _____ :

FLOOR NO _____ .

SIGN _____ :DATE _____ :

(MANAGER/AUTHORIZED SIGNATORY)

Fig: 37. Sample display indicating maximum occupancy to avoid overcrowding and stampede

25. Glossary

Accessibility- Accessibility refers to the characteristic of products, services and environment designed in a way that people with different disabilities can independently use the facilities.

Accessible Route- An accessible route is a continuous, unobstructed path connecting all accessible elements and spaces in a building, facility, or site etc.

Accessible format- Formats that are an alternative to standard print and are accessible to people with disabilities. It may include large print, recorded audio and electronic formats, and Braille.

Acoustic- Relating to sound or hearing.

Ambulant disabled- The term 'ambulant disabled' refers to people with a wide range of disabilities who are not wheelchair users. This could include, for example, people who may be able to walk using mobility devices such as crutches, walkers etc.

Area of refuge- An area of refuge is a location in a building designed to hold occupants during a fire or other emergency, when evacuation may not be safe or possible. Occupants can wait there until rescued or relieved by firefighters.

Architectural Design- A general term to describe buildings and other physical structures. The art and science of designing buildings structures.

Assistive device- The term is used for devices that help people overcomes disabling conditions such as mobility, vision, mental, dexterity or hearing loss/ Devices used to improve functional abilities of persons having reduced mobility and sensory issues.

Braille- Braille is a system of touch reading and writing for blind persons in which raised dots represent the letters of the alphabet. Braille also contains equivalent for punctuation marks and provides symbols to show letter groupings. Braille is read by moving the hand or hands from left to right along each line.

Color contrast- The change in the appearance of a colour surrounded by another colour. It usually helps to help persons with visual disability in orientation.

Congregational- a group of people assembled for religious worship.

Circulation Path- Within buildings, circulation spaces are spaces that are predominately used for circulation, such as entrances, foyers and lobbies, corridors etc.

Drop-off points- Points for dropping off and picking up passengers/visitors on the designated routes. Parking of the vehicles are not allowed at Drop- off points.

Directional signage- Graphic designs, as symbols, emblems, or words, used especially for identification or as a means of giving directions or change in directions Egress.

Emergency evacuation chair- Emergency evacuation chairs, also known as stairway evacuation chair, fire evacuation chairs allow wheel chair users or people with reduced mobility to be evacuated quickly and safely down stairs in the event of an emergency.

Evacuation - Evacuation is the immediate and urgent movement of people away from the threat or actual occurrence of a hazard.

Grab bars- Is a graspable bar attached to the wall in a shower or near a bathtub or in the toilet as an assistance to a user in maintaining balance or getting in and out.

Handrail - A handrail is a rail that is designed to be grasped by the hand to provide stability or support.

Hearing enhancement system- Is an assistive listening system that provides access to facilities for those with a hearing impairment. It takes a sound source and transfers it directly to a hearing aid without background noise.

International Symbol of Accessibility- A symbol used to identify buildings and facilities that are barrier free and therefore accessible to persons with disability with restricted mobility, including wheelchair users.

Inaccessible- Unable to use or reach a place because of barriers.

Lux- Unit to measure illumination.

Optical Character Reader (OCR) - It is a widespread technology to recognize text inside images, such as scanned documents and photos.

Pictograms- A pictorial symbol that represents activities, facilities, or concepts.

PRM- Persons with Reduced Mobility.

QR codes- A QR code (quick response code) is a type of 2D bar code , which is used to provide easy access to information through a smart phone.

Riser- The risers are the vertical height of the individual stairs.

Tactile ground surface indicator (TGSi) - is a system of textured ground surface indicator found on footpaths, stairs, and station platforms and at other public to assist pedestrians who are visually impaired.

Tread- The tread is the part of the stairs you stand on.

Thresholds- Level difference between two surfaces that may act as a barrier or tripping hazards.

Utilization space- Space available for wheelchair movement and turning.

Vernacular- The language or dialect spoken by the people in a particular country or region.

Wuzu- The ritual washing of face, hands and feet before every prayer (Namaz) in Islam



DIGNITY FOR PEOPLE
WITH REDUCED MOBILITY

SVAYAM
Jindal Centre
12, Bhikaji Cama Place
New Delhi - 110 066, India

